

Zenith Dimensional Drawing

UNIT SPECIFICATIONS

- Rated Load: 350 lbs.
- Speed: 22 feet per minute
- Travel: 20' Maximum
- Electrical Requirement: 120 VAC grounded outlet
- Motor: AC Model-1/3 HP 90VDC, DC Model-1/3 HP 24VDC
- Incline Limits: 30° to 45°
- Brake: Self-locking worm gear
- Drive System: 3/16" dia. aircraft cable
- Controls: Constant pressure with optional keylocks
- Safety: Slack Rope
- ETL Listed - Control No. 3148125
- Stairway lift meets ASME A18.1-2005 section 4 & 7
- ANSI/NFPA 70
- CAN/CSA B44.1/ASME-A17.5-11

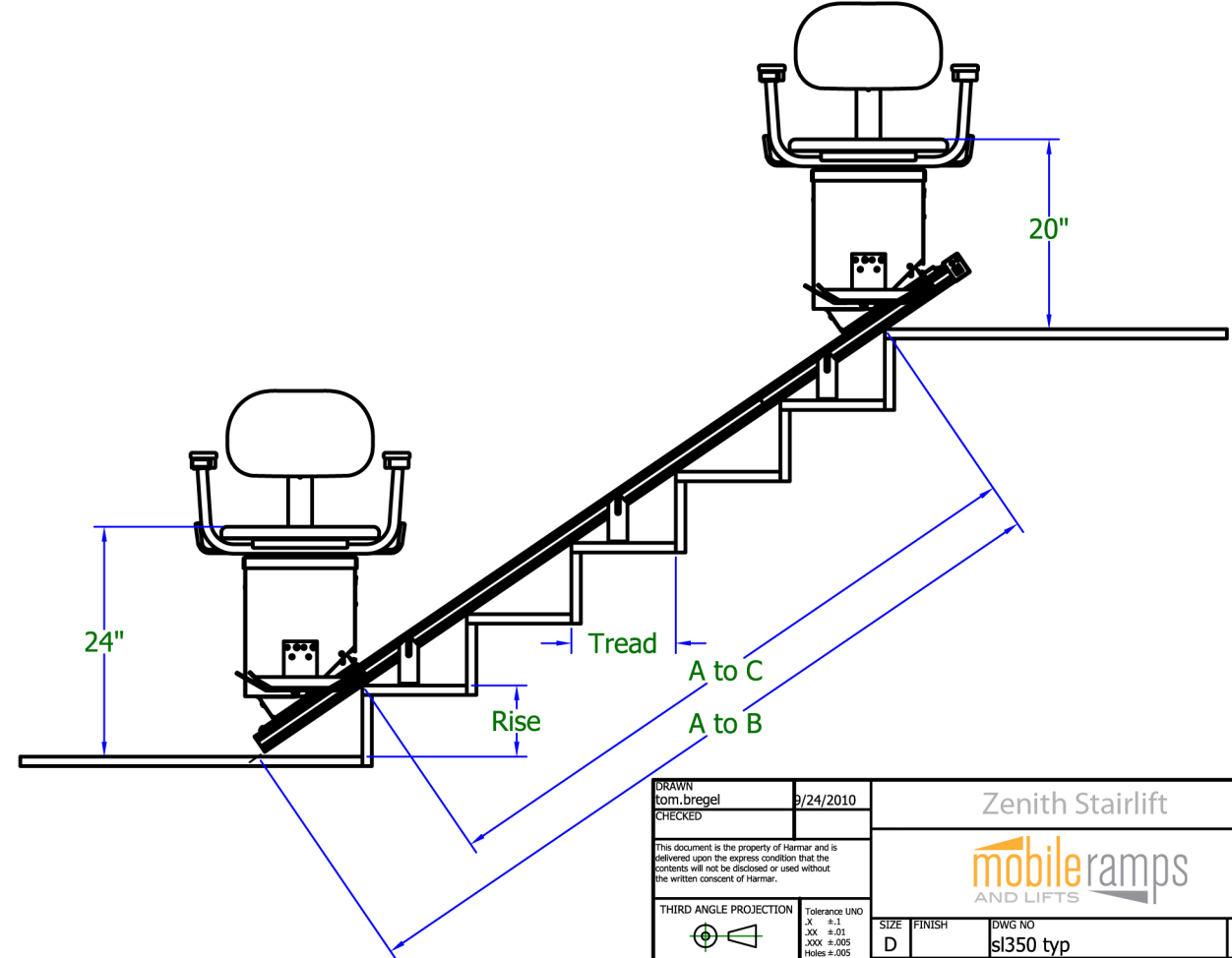
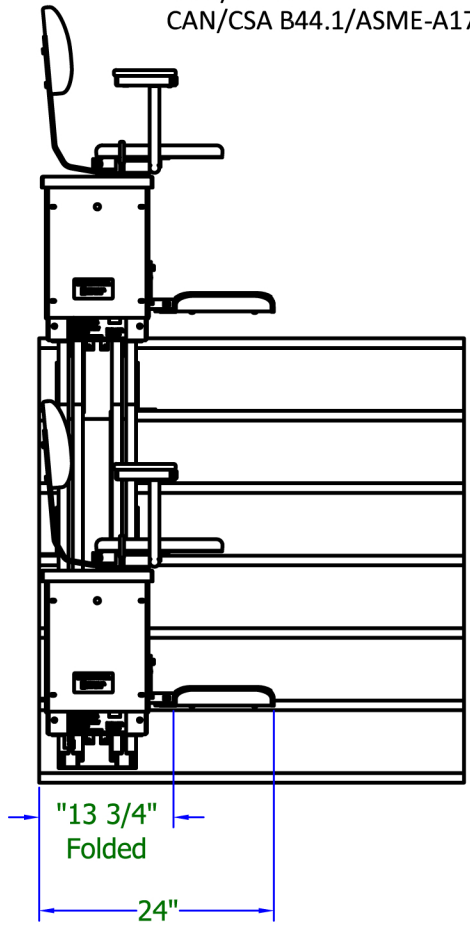
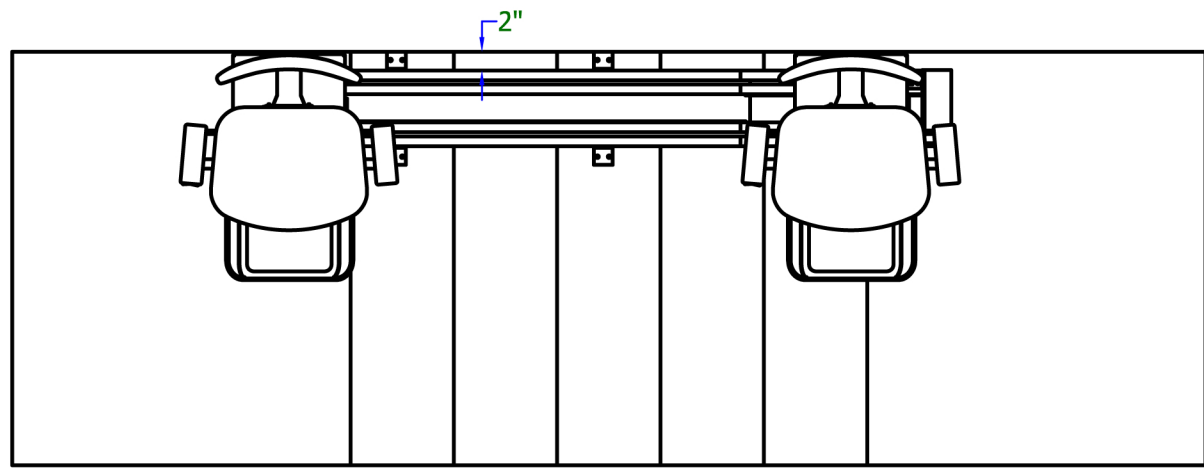

DRAWN tom.bregel		9/24/2010		Zenith Stairlift				
CHECKED								
<small>This document is the property of Harmar and is delivered upon the express condition that the contents will not be disclosed or used without the written consent of Harmar.</small>				<small>SIZE FINISH</small> D		<small>DWG NO</small> sl350 typ		<small>REV</small>
<small>THIRD ANGLE PROJECTION</small> 		<small>Tolerance UNO</small> .X ±.1 .XX ±.01 .XXX ±.005 Holes ±.005 Ang ±.5°		<small>SCALE</small>		<small>SHEET</small> 1 OF 1		